

RECESSED COMBINATION UNIT



CONTEMPORARY SERIES 2017A

- Combination 2-in-1 unit:
Towel dispenser and waste receptacle

- Satin finish stainless steel

Overall Dimensions
330mm W x 1395mm H x 153mm D

CONSTRUCTION:

CABINET: Fabricated of type 304 (18-8) 22 gauge stainless steel with exposed surfaces in architectural satin finish. Welded construction with seamless corners and burr-free edges.

DOOR: Fabricated of type 304 (18-8) 18 gauge stainless steel, 13mm return for maximum rigidity. Concealed full-length stainless steel piano hinge, 2 tumbler locks keyed as other Bradley units.

TOWEL DISPENSER: Fabricated of type 304 (18-8) 22 gauge stainless steel. Rolled edge on dispenser opening.

WASTE RECEPTACLE: Fabricated of satin stainless steel fully welded.

CAPACITY:

Towel Dispenser - holds Bradley Model 2001 paper hand towels.
Waste Receptacle Insert - 22 litres.

OPERATION:

Unit holds paper hand towels without the use of special adaptors.
Waste receptacle insert removable by unlocking receptacle door.

INSTALLATION:

Recessed unit requires Rough Wall Opening 290mm W x 1357mm H x 150mm D (semi-recessed unit only 95mm deep).

Secure to framing with mounting screws at holes provided.

GUIDE SPECIFICATION:

Recessed combination towel dispenser and waste receptacle shall be fabricated of heavy gauge type 304 (18-8) stainless steel with exposed surfaces in satin finish. Cabinet door of 18 gauge stainless steel with full length concealed piano hinge and secured by 2 tumbler locks.

MODEL 2017A

Options:

2017A-10 Semi Recessed

2017A-11 Surface Mounted

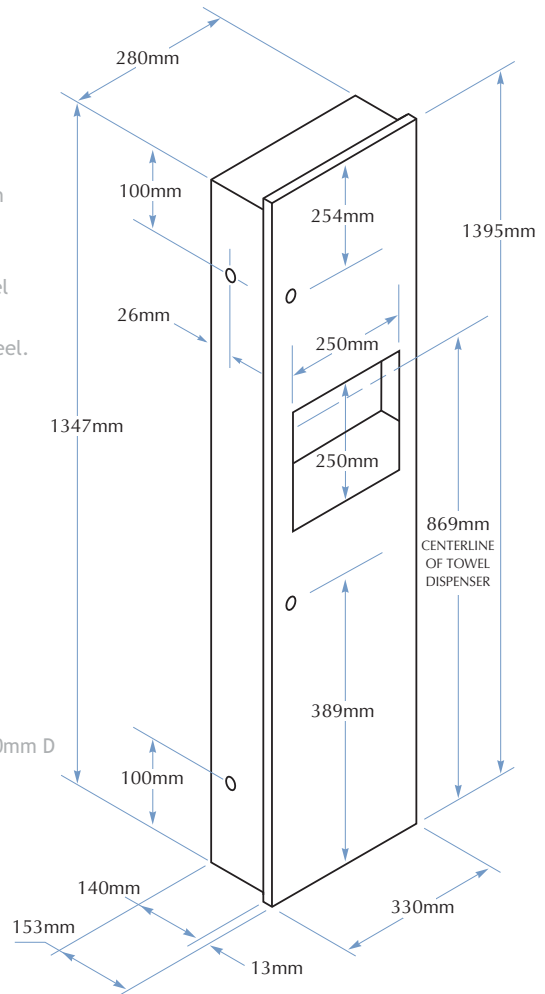

TOLL FREE 1300 364 561

The manufacturer reserves the right to make changes in design and material without formal notice and without incurring obligation.

Bradley
AUSTRALIA.COM