

## WALL MOUNTED UNIT

## MODEL 220-1900



### OVATION SERIES HAND DRYER 220-1900

- Compact ABS plastic casing
- Modern design
- Ideal for executive washroom and low volume areas

Overall Dimensions  
210mm W x 285mm H x 145mm D

### CONSTRUCTION:

**OUTER CASE:** Outer case manufactured of white ABS plastic, featuring vandal resistant key.

**MOTOR:** 1000w energy and cost saver.

### ELECTRICAL SPECIFICATIONS:

**ELECTRICAL SUPPLY:** 240V / 50Hz / 4.17A  
**ELEMENT:** 980W / 95°C / 8A/250V  
**AIR VELOCITY:** 8.8m/sec  
**NOISE LEVEL:** 73db  
**NETT WEIGHT:** 2kg  
**PROTECTION CATEGORY:** IPX1

### RECOMMENDED INSTALLATION HEIGHT

Men's Washroom	1200mm
Women's Washroom	1150mm
Children's Washroom (ages 11-15)	1110mm
Children's Washroom (ages 5-10)	850mm
Disabled Person's Washroom	1000mm

### OPERATION:

Activation by infra-red (touch free) sensor.

### INSTALLATION:

Secure to wall through back-plate with mounting screws provided.

### GUIDE SPECIFICATION:

Surface mounted automatic hand dryer shall be manufactured of ABS plastic, featuring vandal-resistant key. Motor long-life energy saver. 10 to 15 second drying time.

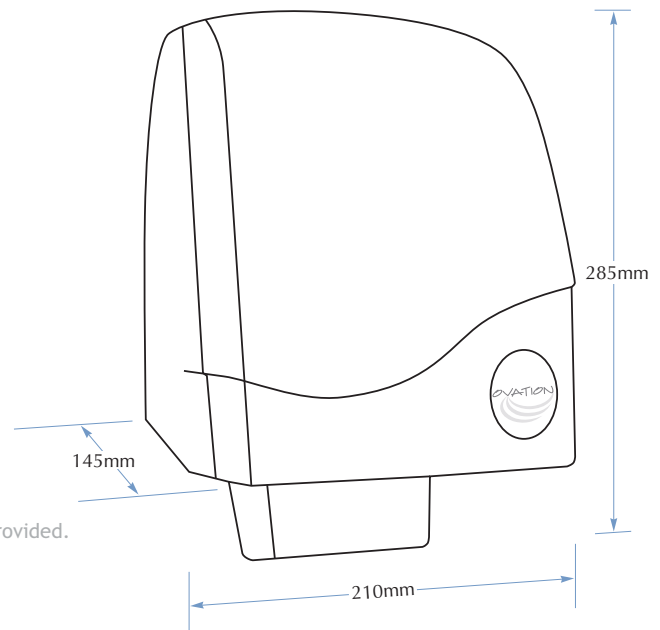

**TOLL FREE 1300 364 561**

The manufacturer reserves the right to make changes in design and material without formal notice and without incurring obligation.

**Bradley**  
AUSTRALIA.COM