

RECESSED MULTI-PURPOSE UNIT



MULTI-PURPOSE 2291 RETRO SERIES

- Combination 2 in 1 unit:
towel dispenser/waste receptacle

- Satin finish stainless steel

Overall Dimensions
356mm W x 711mm H x 102mm D

CONSTRUCTION:

CABINET: Fabricated of type 304 (18-8), heavy gauge stainless steel with exposed surfaces in architectural satin finish. All welded construction.

FLANGE: Fabricated of type 304 (18-8), 22 gauge stainless steel with exposed surfaces in architectural satin finish. One piece seamless construction, 25mm wide with 7mm return.

DOOR: Fabricated of type 304 (18-8), 22 gauge stainless steel with full length piano hinge and tumbler lock keyed as other Bradley units.

TOWEL DISPENSER: Fabricated of type 304 (18-8), 22 gauge stainless steel. Rolled edge on dispenser opening.

WASTE RECEPTACLE INSERT: Fabricated of type 304 (18-8), 22 gauge stainless steel.

CAPACITY:

Towel Dispenser - holds Bradley Model 2001 paper hand towels.

Waste Receptacle Insert - 8 litres.

OPERATION:

Towel dispenser holds paper towels without the use of special adaptors.

Waste receptacle insert removable.

INSTALLATION:

Recessed unit requires Rough Wall Opening 315mm W x 670mm H x 100mm D. (Semi-recessed unit only 51mm deep.) Secure to framing with mounting screws (included) at holes provided.

GUIDE SPECIFICATION:

Recessed combination paper towel dispenser and waste receptacle shall be fabricated of heavy gauge type 304 (18-8) stainless steel with exposed surfaces in architectural satin finish .

MODEL 2291

Options:

2291-10 Semi-Recessed

2291-11 Surface Mounted

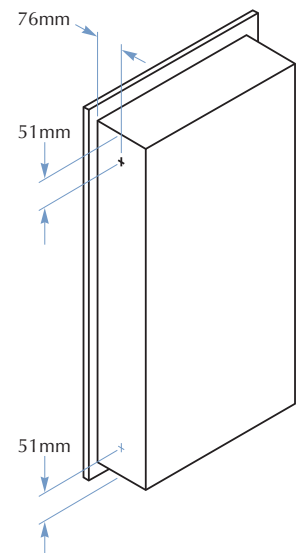
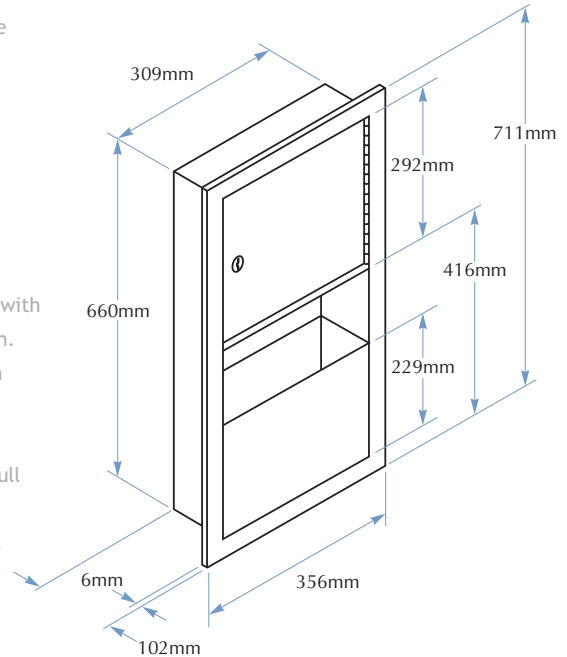

TOLL FREE 1300 364 561

The manufacturer reserves the right to make changes in design and material without formal notice and without incurring obligation.

Bradley
AUSTRALIA.COM