

RECESSED COMBINATION UNIT



CONTEMPORARY SERIES 3847

- Combination 2-in-1 unit:
Hand dryer and waste receptacle
- Contemporary design in satin finish stainless steel
- Heavy duty hand dryer
- Large capacity

Overall Dimensions
360mm W x 1300mm H x 185mm D

CONSTRUCTION:

CABINET: Fabricated of 22 gauge stainless steel with exposed surfaces in 304 (18-8) architectural satin finish. All welded construction with seamless corners and burr-free edges.

DOOR: Fabricated of type 304 (18-8), 18 gauge stainless steel with 13mm return for maximum rigidity. Concealed full length stainless steel piano hinge and two tumbler locks as other Bradley units.

HAND DRYER: Heavy duty auto hand dryer Bradley model 220-250A.

WASTE RECEPTACLE: Fabricated of 22 gauge stainless steel. All welded construction.

CAPACITY:

Waste receptacle - 30 litre.

OPERATION:

Hand dryer is infrared sensor operated by placing hands into second hole below dryer as indicated. Waste receptacle is large capacity allowing towel to fall to base, alleviating messy washroom.

INSTALLATION:

Recessed unit requires Rough Wall Opening 320mm W x 1270mm H x 175mm D (semi-recessed unit only 90mm deep). Set opening minimum 100mm from finished floor. Hand dryer requires 15 amp power supply.

GUIDE SPECIFICATION:

Recessed combination hand dryer and waste receptacle shall be fabricated of 18 and 22 gauge stainless steel with exposed surfaces in architectural satin finish.

MODEL 3847

Options:

3847-10 Semi Recessed

3847-11 Surface Mounted

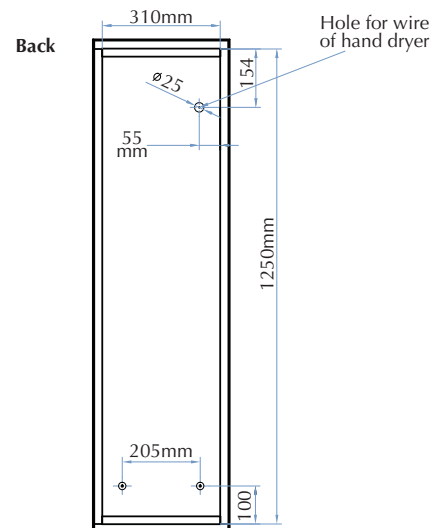
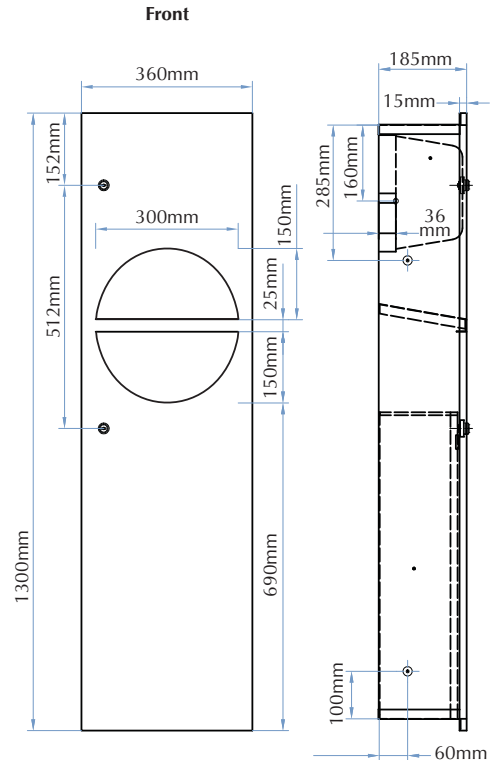

TOLL FREE 1300 364 561

The manufacturer reserves the right to make changes in design and material without formal notice and without incurring obligation.

Bradley
AUSTRALIA.COM