

## RECESSED NAPKIN DISPOSAL UNIT

# MODEL 4731-15



### NAPKIN DISPOSAL 4731-15

- Satin finish stainless steel

Overall Dimensions  
324mm W x 435mm H x 102mm D

### CONSTRUCTION:

**CABINET:** Fabricated of type 304 (18-8), heavy gauge stainless steel. All welded construction.

**FLANGE:** Fabricated of type 304 (18-8), 22 gauge stainless steel with exposed surfaces in architectural satin finish. One piece seamless construction, 25mm wide with 7mm return.

**WASTE RECEPTACLE:** Fabricated of type 304 (18-8), 22 gauge stainless steel with tumbler lock keyed as other Bradley units.

**PUSH FLAP DOOR:** Fabricated of type 304 (18-8), 22 gauge stainless steel with exposed surfaces in architectural satin finish. Heavy duty stainless steel piano hinge. Self-closing flap door.

### CAPACITY:

5.7 litres (1.5 gal./ .2 cu. ft.)

### OPERATION:

Waste container removable with finger grip. Furnished with waxed paper liner. Additional liners available from Bradley Australia.

### INSTALLATION:

Requires rough wall opening 289mm W x 391mm H x 102mm D.

Top of wall opening 838mm above finished floor. Secure to framing with mounting screws (included) at holes provided.

Shim at screw points as required.

### GUIDE SPECIFICATION:

Recessed napkin disposal shall be fabricated of type 304 (18-8), stainless steel with exposed surfaces in satin finish.

Self-closing push flap door secured by piano hinge.

Removable stainless steel receptacle with tumbler lock.

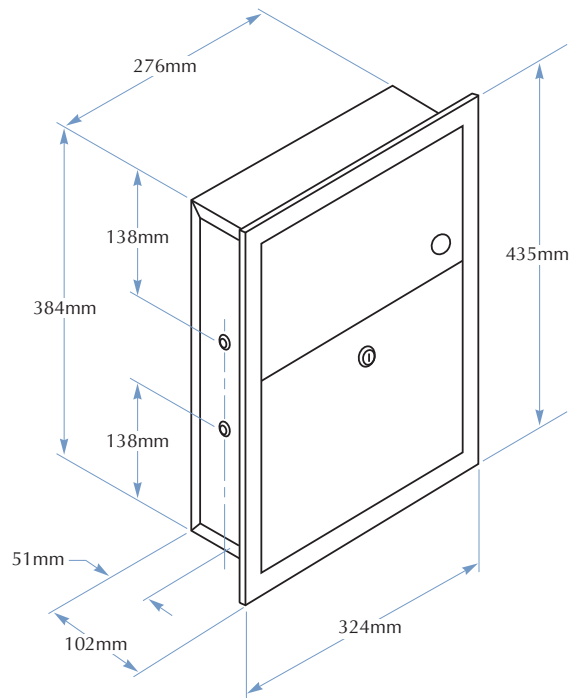

**TOLL FREE 1300 364 561**

The manufacturer reserves the right to make changes in design and material without formal notice and without incurring obligation.

**Bradley**  
AUSTRALIA.COM