

RECESSED TOILET TISSUE DISPENSER

MODEL 5412



MODEL 5412

- Satin finish stainless steel

- Double roll

Overall Dimensions
193mm W x 314mm H x 135mm D

CONSTRUCTION:

FLANGE: Fabricated of type 304 (18-8), 22 gauge stainless steel with exposed surfaces in architectural satin finish. Flange of one piece seamless construction, 25.5mm wide with 6.35mm return.

CABINET: Fabricated of type 304 (18-8), 22 gauge stainless steel with exposed surfaces in architectural satin finish. Welded construction with burr-free edges.

SERVICE DOOR: Fabricated of type 304 (18-8), 22 gauge stainless steel with exposed surfaces in architectural satin finish and tumbler lock keyed as other Bradley units. Hinged at base.

SPINDLES: Fabricated of molded polyethylene.

CAPACITY:

Holds two standard core toilet tissue rolls through 127mm in diameter. (Bradley Model 4004 x 2 Ply and Bradley Model 4008 x 1 Ply)

OPERATION:

Cabinet holds two rolls of 114.5mm x 127mm standard core toilet tissue, one above the other. When first roll is used-up, fresh roll automatically drops down for use. Unique retaining mechanism prevents use of spare roll until first roll is completely used. Spindles non removable by user. Hinged door permits access to storage compartment for servicing of unit.

INSTALLATION:

Requires Rough Wall Opening 146mm W x 267mm H x 102mm D. Top of wall opening 915mm above finished floor. Secure to framing with mounting screws (included) at holes provided. Shim at screw points as required.

GUIDE SPECIFICATION:

Recessed dual roll toilet tissue dispenser shall be heavy gauge satin finish stainless steel and hold two standard core toilet tissue rolls.

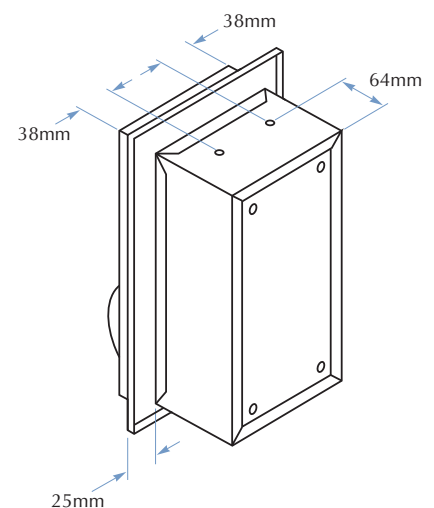
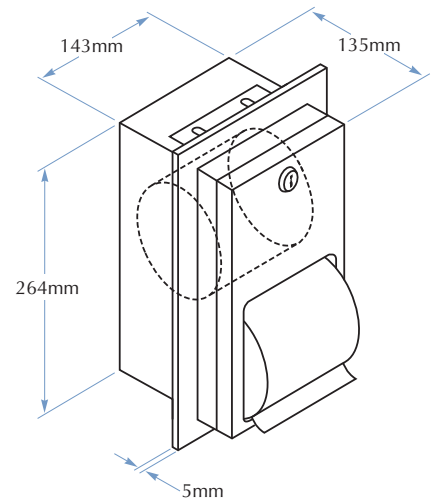

TOLL FREE 1300 364 561

The manufacturer reserves the right to make changes in design and material without formal notice and without incurring obligation.

Bradley
AUSTRALIA.COM