

RECESS MOUNTED LIQUID SOAP DISPENSER

MODEL 644



SOAP DISPENSER 644

- Satin finish stainless steel
- 1.2 litre capacity

Overall Dimensions
152mm W x 254mm H x 102mm D

CONSTRUCTION:

FLANGE: Fabricated of type 304 (18-8), 22 gauge stainless steel with exposed surfaces in architectural satin finish. One piece seamless construction, 25mm wide with 7mm bevelled edges.

CABINET: Fabricated of type 304 (18-8), heavy gauge stainless steel.

SOAP VESSEL: Fabricated of type 304 (18-8), 22 gauge stainless steel with exposed surfaces in architectural satin finish. Tumbler lock keyed as other Bradley units.

SOAP VALVE: Fabricated of chrome plated brass with ABS mechanism. Internal Buna-N check valves prevent leakage.

CAPACITY:

1.2 litres of liquid soap. We recommend Bradley model PB609 liquid soap for optimum operation and performance.

OPERATION:

Soap dispenser has removable cover for filling and cleaning. Push-in valve dispenses measured amounts of liquid soaps, synthetic detergents and antiseptic solutions. Sight gauge indicates refill time. Door secured with tumbler lock.

INSTALLATION:

Requires rough wall opening 114.5mm W x 216mm H x 102mm D. Secure to framing with mounting screws (included) at holes provided. Shim at screw points as required.

GUIDE SPECIFICATION:

Recessed liquid soap dispenser shall be fabricated of type 304 (18-8), heavy gauge stainless steel with exposed surfaces in satin finish.

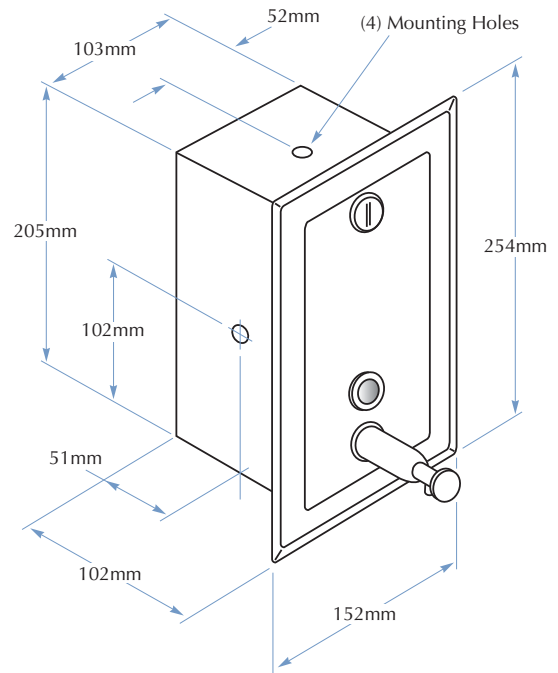

TOLL FREE 1300 364 561

The manufacturer reserves the right to make changes in design and material without formal notice and without incurring obligation.

Bradley
AUSTRALIA.COM