

SURFACE MOUNTED LIQUID SOAP DISPENSER



SOAP DISPENSER 661

- 2.4 litre capacity shelf type dispenser
- Satin finish stainless steel

Overall Dimensions
445mm W x 83mm H x 133mm D

CONSTRUCTION:

HINGED SHELF: Fabricated of type 304 (18-8), 20 gauge stainless steel with exposed surfaces in architectural satin finish.

RESERVOIR: Fabricated of type 304 (18-8), 20 gauge stainless steel with exposed surfaces in architectural satin finish. Heliarc welded seams.

SOAP VALVE: ABS plastic mechanism with stainless steel button cover.

CAPACITY:

2.4 litres of liquid soap. We recommend Bradley model PB609 liquid soap for optimum operation and performance.

OPERATION:

Pump type valve draws liquid soap from bottom of reservoir. Dispenses measured amount of liquid soaps, synthetic detergents and antiseptic solutions. Sight gauge indicates refill time. Hinged shelf secured by concealed friction latch and 2 locking bars.

INSTALLATION:

Secure dispenser with mounting screws (included). If mounted under a horizontal projection, allow 127mm clearance for filling.

GUIDE SPECIFICATION:

Shelf type soap dispenser shall be fabricated of 20 gauge 18-8 stainless steel. Soap valve has ABS plastic mechanism with stainless steel button cover. Concealed friction latch for cover.

MODEL 661

Options:

661 One Soap Valve

662 Two Soap Valves

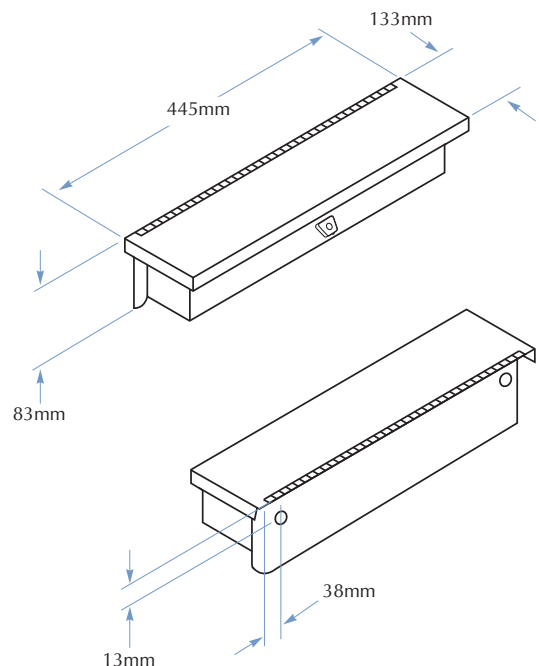

TOLL FREE 1300 364 561

The manufacturer reserves the right to make changes in design and material without formal notice and without incurring obligation.

Bradley
AUSTRALIA.COM