

SURFACE MOUNTED TILT MIRROR WITH SHELF



TILT MIRROR WITH SHELF 7405

- Fixed tilt
- Welded corners shall be polished to a uniform satin finish
- Mirror has full stainless steel surround
- Mirror glass conforms to AS1288/2006 Australian safety glass standards

Overall Dimensions
AS1428 size is 450mm W x 950mm H
[Model 7405-1838] or specify width and height

CONSTRUCTION:

FRAME: Fabricated of type 304 (18-8), 20 gauge stainless steel, corners heliarc welded and ground smooth to satin finish. 20 gauge angle stiffeners welded to frame provide additional rigidity.

BACK: Fabricated of zinc seal, secured to frame with concealed screws equipped with integral horizontal 304 stainless steel hanging brackets.

MIRROR: Fabricated of first quality 6mm float glass triple silver plated with electro-copper plated layer and thermosetting infrared cured paint backing with Poly-Glaze protective finish. Special webbed backing conforms to AS1288/2006 Australian safety glass standards.

WALL HANGER: Fabricated of 18 gauge cold rolled steel, all welded construction to form rigid template.

SHELF: Fabricated of type 304 (18-8), 20 gauge stainless steel with exposed surfaces in architectural satin finish. Welded to frame.

SHELF BRACKETS: Fabricated of 16 gauge stainless steel are provided on units exceeding 1220mm width.

INSTALLATION:

Secure concealed mounting bracket to wall with screws (not included) at holes provided. NOTE: Provide in-wall backing at mounting screw locations. Position mirror over mounting bracket to engage hanger tabs. Slide mirror down and lock into position.

GUIDE SPECIFICATION:

Fixed tilt mirror shall be framed with type 304 (18-8), 20 gauge stainless steel with 20 gauge concealed stiffeners. Welded corners shall be polished to a uniform satin finish. Mirror shall be of first quality 6mm float glass with special webbed backing - conforms to AS1288/2006 Australian safety glass standards and protected by a shock absorbing, waterproof foam filler with Poly-Glaze protective finish, equipped with integral horizontal hanging brackets and separate wall hanger for concealed mounting.

MODEL 7405

Options:

7405-1838 - 450mm W x 950mm H (AS1428)

7405-2438 - 600mm W x 950mm H (AS1428)

7405-1830 - 450mm W x 750mm H

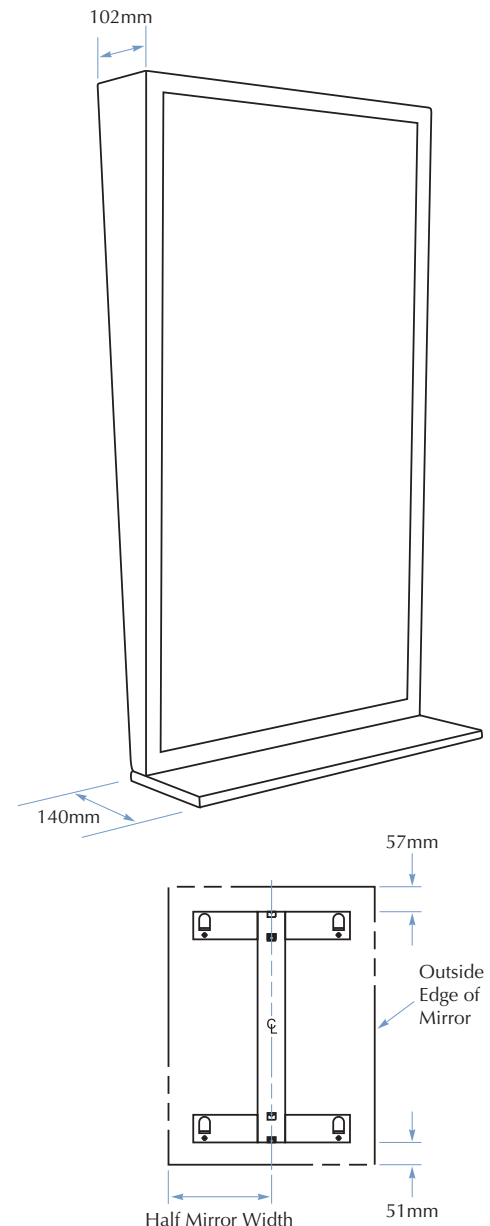

TOLL FREE 1300 364 561

The manufacturer reserves the right to make changes in design and material without formal notice and without incurring obligation.

Bradley
AUSTRALIA.COM